

## **THEORETICAL MODELING OF MULTIDEGREES OF FREEDOM ULTRASONIC MOTORS FOR MICROMACHINE APPLICATIONS**

**Claudia BORDA, Marinela MARINESCU, Delicia ARSENE, Larisa BUTU**

University "Politehnica" of Bucharest, email: [ctistere@yahoo.com](mailto:ctistere@yahoo.com)

**Abstract:** The aim of this paper is to conceive, to develop a theoretical modeling and to characterize new multi-degree of freedom piezoelectric motors, After a short description of the operating principles specific to the piezomotors, the mechanical and tribological assumptions made for the driving mechanism of the rotor are briefly described. These devices are respectively based on the conversion, through frictional contact, of bending vibrations sustained in one or several vibrators into rigid body displacements of a moving element.

**Keywords:** ultrasonic motor, kinematic pair, multi-degree of freedom, micromanipulator.

### **1. INTRODUCTION**

During the last decade, many applications for ultrasonic motors have been proposed, particularly in Japan, but also recently in the USA and Europe. It is believed that, in the near future, ultrasonic motors will replace electromagnetic motors to some extent. Conventional electromagnetic motors cannot meet the demand for miniaturization of future motors and for more precise and sophisticated positioning without generating magnetic noise. Instead, ultrasonic motors will be used, whose efficiency is insensitive to size and whose power: weight ratio, response time and positioning accuracy are excellent compared with those of other motors. Other advantages of these motors are low speed and high torque without using additional gears, a wide velocity range, compact size and light weight.

Almost all of the proposed ultrasonic motors are based on a stator (active element) and a slider, rotor (activated element). On the surface of the stator, an elliptical motion is induced by a piezoelectric driving component. This elliptical motion may be generated by the superposition of two standing waves or by generating a traveling wave. The first is the more commonly used approach. The stator surface motion is transmitted through frictional force to the rotor or slider. In general, the natural resonance frequency of the stator is used as a driving frequency of the motor which provides a large elliptical motion. The name "ultrasonic" indicates that the usual driving frequency is in the range 20 - 200kHz.

Microsystems, and especially microrobots, require the development of advanced actuators with small dimensions, simple mechanical structure and high reliability. This research currently leads to the development of numerous actuators such as micromotors which exploit electromagnetic [1], and electrostatic forces as well as magnetostrictive [4] or piezoelectric converters. These devices open up a world of new possibilities. Recently results have shown that current projects relating to multidegrees of freedom piezoelectric vibromotors will constitute a major step for the future development of micromanipulators and microrobots [2,3]. To provide a microrobot with both transportation and micromanipulation capabilities, various designs of ultrasonic motors can be used.

This paper presents, in a first part, a new concept for designing piezoelectric micromanipulator with six degrees of freedom, which combines the ultrasonic motor capability of precise manipulation with the mobility of the whole microrobot system. In the second part, new ultrasonic motors which convert by friction traveling wave mechanical vibrations into several rigid body displacements of a moving element, will be discussed.

### **2. SIX DEGREES OF FREEDOM PIEZOELECTRIC MICROMANIPULATOR**

Kinematic chains are usually defined, at a macroscopic scale, as a group of rigid bodies connected by means of lower pairs, which are

alternatively revolute or translation pairs with one degree of freedom. Recent results have shown that multidegree of freedom ultrasonic motors will constitute a major step for the future development of micro robots.

Any ultrasonic motor with several degrees of freedom represents a kinematic pair of the corresponding class with a force closure [5]. Therefore, it is expedient to consider designs of such ultrasonic motors on the basis of the kinematic pair classification. These ultrasonic motors have been applied to the design of a

six degrees of freedom mobile piezoelectric micromanipulator (fig.1). Comparing the design schematics of an ordinary manipulator with active kinematic pair and the same number of degrees of freedom it can be seen that the continuous increase of the number of degrees of freedom in a ordinary schematic leads to a stiffness decrease and an increase in the time for transient processes.

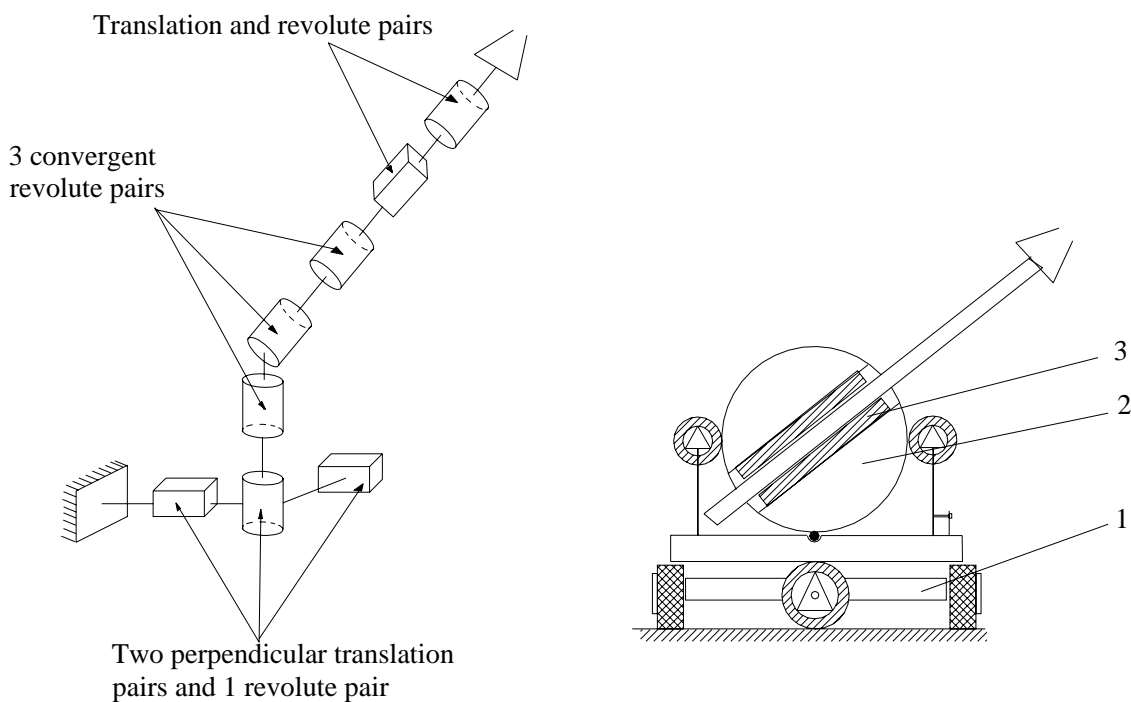

*Fig. 1. Piezoelectric micromanipulator with 6 DOF*

The total stiffness of the micromanipulator gripper - to - base kinematic chain is higher when using ultrasonic motors, and provides high accuracy characteristics of the micromanipulator. As we can see, we need only three ultrasonic motors, (1) piezoelectric microtranslator with three degrees of plane motion, (2) piezoelectric spherical micromotor with three degrees of revolution motion and (3) piezoelectric cylindrical micromotor with two degrees of linear motion and rotation of freedom to perform a conventional manipulator with six degrees of freedom and seven types of motion. The piezoelectric micromanipulator consists of a mobile platform performed by an

ultrasonic microtranslator with three degrees of freedom and a manipulation tool performed by a piezoelectric spherical micromotor (three degrees of freedom:  $\theta_x, \theta_y, \theta_z$ ).

The piezoelectric microtranslator is able to move forward, backward, sideways and turn. The spherical micromotor is composed by a spherical rotor drive by four elementary stators. The stators are located in a same symmetry plane and at four cardinal points. A cylindrical pair (IV- class with two degrees of freedom:  $z, \theta_z$ ) will be joined in a symmetry axis of the sphere in order to carry out the micromanipulation tasks.

The piezoelectric microtranslator with three degrees of plane motion is based on

the three-mobile planar kinematic pair of class III of the third type (fig.2,a). This mechanism can be designed, in principle, in the form of one converter, freely lying on the plane. Such ultrasonic motors are sensitive to

loading, because all of the parameters are interconnected. The design with separate converters is relatively easy to build.

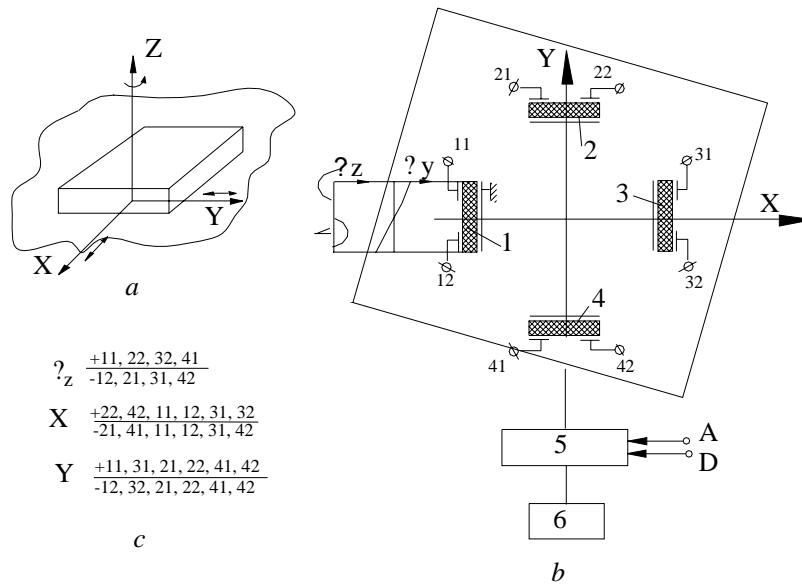

Fig. 2. Piezoelectric microtranslator for the positioning in plane (x, y, θ<sub>z</sub>)

One such schematic is presented in figure 2b, where, the movable object is situated on the converters 1, 2, 3 and 4. each converter is shaped as a piezoceramic ring [6], executing traveling wave (fig.3).The forced closure of the contact is accomplished by its own weight, or by additional constraints. In the control circuit, the electrodes of the converters are connected to the output O1 of commutation block 5 (fig.2b), to one of whose inputs high frequency the generator 6 is connected. The control of block 5 is accomplished according to the assigned coordinates (input A). There is also a possibility of work in a closed loop system, with a position feedback. In this case the signal of the transducers enter the input D. The circuit of the electrodes commutation is presented in fig.2c. The diagram, presented in fig.2b, is reversible, when the moving member is attached to the converter, then the motion is unlimited along all three coordinates. This is effectively used in the desing of the micromanipulators.

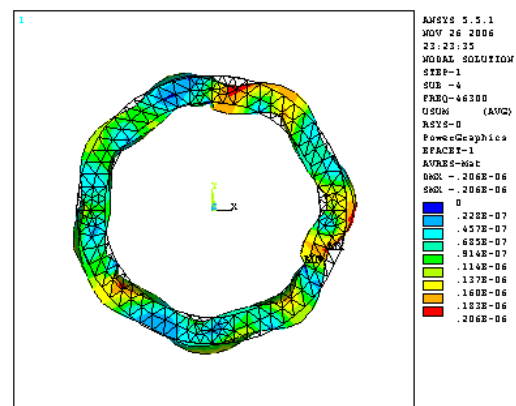
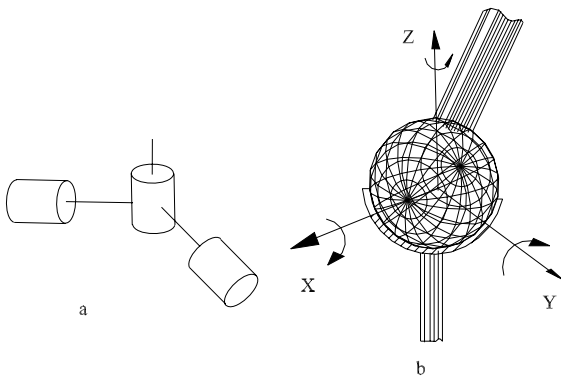

Fig. 3. Experimental visualisation of mode shapes.

The development of tridimensional micromanipulators at a millimetric scale incites numerous investigations in the field of spherical micromotors. The most interesting solutions aim at substituting conventional combinations of revolute pairs of class V -one degree of freedom (fig.4,a) by ball-and socket joints of class III - three degrees of freedom (fig.4,b). The current devices are unfortunately complex and expensive.



**Fig. 4. Ball- and – socket joint morfologies.**

The mechanism recently developed is a spherical micromotor which is easy to build, economic, and capable of operating with traveling wave technology [7]. The geometry of the device is described by figure 5. The displacements of the rotor are performed by four elementary stators, located in a same symmetry plane and at four cardinal points. Two diametrically opposed stators are employed to carry out the multidirectional rotor drive. The rotor - stator contact is nearly concentrated at a point in order to reduce the holding torque along this axis of rotation. The statoric elements are vibrating shells of simple geometry and inexpensive to manufacture.

The external nominal load is applied by an elastic beam. The geometry of the beam is characterized by the circular mean line and equilateral section. This loading allows the mechanical symmetries necessary to generate a traveling wave to be obtained.

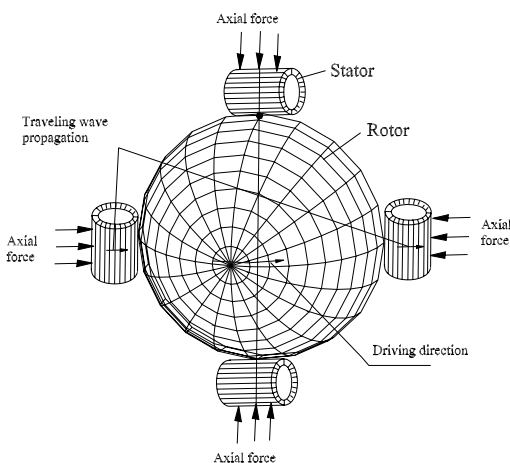

**Fig. 5. Mechanical structure of spherical ultrasonic micromotor.**

The Hertz theory allows the point contact mechanism at the rotor-stator interface to be described (fig.6). The equations defining respectively the sphere and the cylinder:

$$\begin{cases} x^2 + y^2 + z^2 = R_s^2 \\ y^2 + z'^2 = R_c^2 \end{cases} \quad (1)$$

Allow the following relations to be written:

$$z - R_s = \frac{x^2}{2R_s} - \frac{y^2}{2R_s}; \quad z' + R_c = \frac{y^2}{2R_c} \quad (2)$$

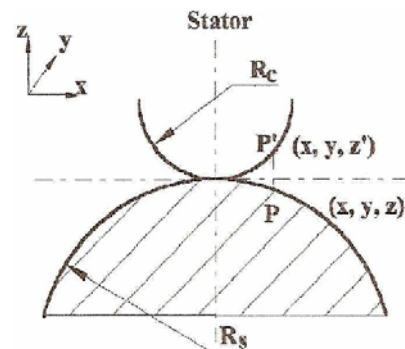

**Fig. 6. The rotor - stator interface.**

The initial length between two points of stator and rotor located on the same straight line parallel to the z-axis is then given by:

$$(z - R_s) - (z' + R_c) = \frac{-x^2}{2R_s} - y^2 \left( \frac{1}{2R_s} + \frac{1}{2R_c} \right) \quad (3)$$

and therefore:

$$R' = R_s; \quad R'' = \frac{R_s R_c}{R_s + R_c} \quad (4)$$

where  $R'$ ,  $R''$ , principal curve radii defined as  $1/R' + y^2 / 2R' = 1/R''$  is the initial length between two points respectively of stator and rotor, located on the same straight line parallel to the z- axis.

Microrobots must incorporate several functions, so their parts will be smaller than 1 mm. These parts should be integrated as much as possible to reduce the assembly time. Some may be of sub-micrometre size, and nano-level handling control technology will be required. To realize such nano-level servo operation, not only actuator control but also sensing, materials and mechanism technologies and their synthesis are important. In these cases, the size of the

actuator is not so much important as the configuration and position of the actuators to attain the desired operability. The piezoelectric actuator has high resolution (order of nm) and good response (order of kHz), and generates a large force. It is suitable for nano-servo positioning, and it has frequently been used as a micro-actuator with great success.

### **3. CONCLUSIONS**

In the field of precise manufacturing, the demand for machines with much higher accuracy is increasing, especially for producing specialized components of micro-devices. In order to perform complex tasks, an alternative approach is to develop many micromachines with the practical characteristics of micro-functions. Many applications require the simultaneous use of several such micromanipulators (microassembling, manipulation, transporting etc.).

The new mechanical concepts discussed in this article should allow the industrialization of microsystems possessing numerous degrees of freedom and integrating a minimal number of motors and elementary components. Our future studies will be oriented toward the determination of the

physical and technological limits associated with the miniaturization of similar mechanisms.

### **REFERENCES**

- [1] WAGNER B: Electromagnetic microactuators with multi degrees of freedom, IEEE, 614-617, 1991.
- [2] FLYNN A.M: Piezoelectric micromotors for microrobots, IEEE, vol. 1., no. 1, 1992.
- [3] RAGULSKIS K., : Vibromotors for precision microrobots, English edition, Editor E.Burn, 1988.
- [4] FUJIKAWA F., : Fabrication of comb-shape microactuator for multidegrees of freedom system, IEEE Int'l MEMS, 990-995, 1992.
- [5] AMZA Gh., et al, : Studiul zonei de contact dintre partea activa si partea mobila a unor motoare ultrasonice cu mai multe grade de libertate, Constructia de masini, nr.8-9, 65-70, 1997.
- [6] AMZA Gh., et al.: Modelarea matematica a unui motor ultrasonic cu mai multe grade de libertate, Constructia de masini, nr.8-9, 60-64, 1997.
- [7] AMZA Gh., et al, : Rezultate experimentale privind realizarea unui motor ultrasonic cu 4 grade de libertate, Constructia de masini, nr.8-9, 71-77, 1997.